

1200V/4mΩ SiC MOSFET半桥模块
1200V/4mΩ SiC MOSFET Half Bridge Module

特性	Features
• 超低损耗	Ultra Low Loss
• 高频开关	High-Frequency Operation
• 高温、高湿反偏	High Temperature, Humidity, and Bias Operation
• 低电感设计	Low Inductive Design
• 高电流密度	High current density
• 集成NTC温度传感器	Intergrated NTC temperature sensor
• 来自MOSFET的零关断拖尾电流	Zero Turn-off Tail Current from MOSFET

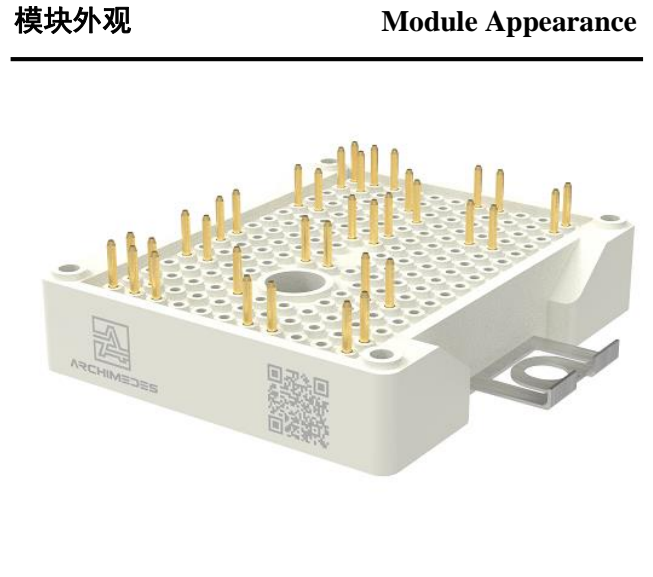

应用	Application
• 电焊机/ Welding Machine	
• 感应加热/ Induction Heating	
• DC-DC转换/ DC-DC Converters	
• 不间断系统/ UPS Systems	

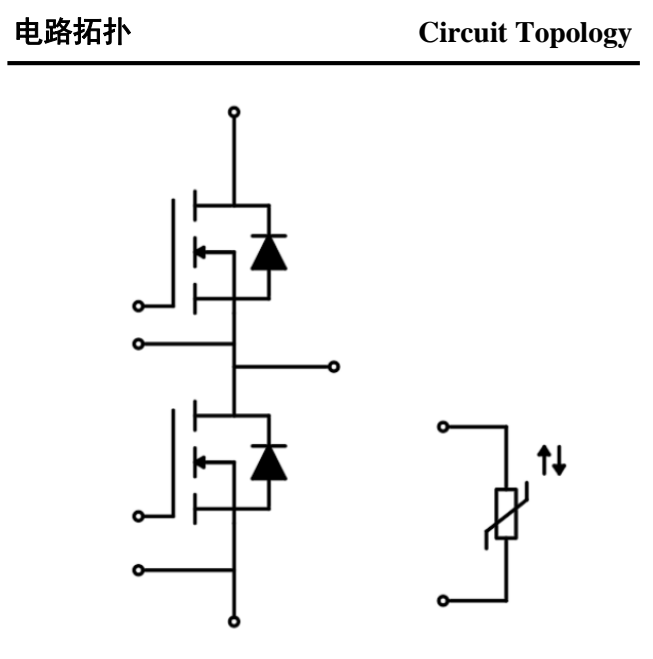

关键参数		Key Parameters		
Parameter	Symbol	Value	Unit	
漏极-源极电压 Drain-Source Voltage	V_{DS}	1200	V	
漏极电流 Drain Current	I_D	240	A	
漏极电流 (脉冲) Drain Current (pulsed)	I_{DM}	480	A	
导通电阻 Static Drain-source On Resistance	$T_{vj}=25^{\circ}C$ $R_{DS(on)}$	4.45	mΩ	
结-壳热阻 Thermal resistance junction to heatsink	R_{thJH}	0.295	K/W	
开通损耗能量 Turn-on energy	$T_{vj}=25^{\circ}C$ $T_{vj}=175^{\circ}C$ E_{on}	4.11 4.40	mJ	
关断损耗能量 Turn-off energy	$T_{vj}=25^{\circ}C$ $T_{vj}=175^{\circ}C$ E_{off}	5.88 6.12		

目录/Table of Contents

封装/ Package	3
最大电特性值/ Maximum Ratings	4
MOSFET 电特性值/ MOSFET Electrical Characteristic	4
体二极管电特性值/ Body Diode Electrical Characteristic	5
热阻 / Thermal Resistance	6
负温度系数热敏电阻/ NTC - Thermistor	6
特征参数图表/Characteristics Diagrams	7
电路拓扑图/ Circuit Diagram	11
封装尺寸/ Package Outlines	12
模块标签信息/ Module Marking Information	13

封装/ Package

绝缘参数/Insulation coordination

Parameter	Conditions	Symbol	Value	Unit
绝缘测试电压 Isolation test voltage	RMS, f = 50Hz, t = 60s	V_{ISOL}	3.0	kV
内部绝缘 Internal isolation	基本绝缘 (class 1, IEC 61140) Basic insulation (class 1, IEC 61140)		Al ₂ O ₃	
爬电距离 Creepage distance	端子至散热器 Terminal to heatsink	d_{Creep}	11.5	mm
爬电距离 Creepage distance	端子至端子 Terminal to terminal	d_{Creep}	6.3	mm
电气间隙 Clearance	端子至散热器 Terminal to heatsink	d_{Clear}	10.0	mm
电气间隙 Clearance	端子至端子 Terminal to terminal	d_{Clear}	5.0	mm
相对电痕指数 Comparative tracking index		CTI	>200	

特征值/Characteristic values

Parameter	Conditions	Symbol	Value			Unit
			Min.	Typ.	Max.	
模块引线电阻, 端子—芯片 Module Lead Resistance, Terminal to Chip		$R_{DD'+SS}$		0.55		mΩ
允许开关的温度范围 Temperature under switching conditions		$T_{vj(op)}$	-40		175	°C
最高结温 $T_{vj max}$		$T_{vj max}$		175		°C
储存温度 Storage temperature		T_{stg}	-40		125	°C
安装力 Mounting force per clamp		F	40		80	N
重量 Weight		G		40		g

最大额定值/ Maximum Ratings

Parameter	Conditions	Symbol	Value	Unit
漏极-源极电压 Drain-Source Voltage	$T_{vj} = 25^{\circ}\text{C}$	V_{DS}	1200	V
漏极电流 Continuous Drain Current	$T_H = 80^{\circ}\text{C}$	I_D	240	A
漏极电流（脉冲） Drain Current (pulsed)	t_p limited by $T_{vj\ max}$	I_{DM}	480	A
栅极-源极电压 Gate-Source Voltage		V_{GS}	-10/+22	V
通态栅极电压 On-state Gate Voltage		$V_{GS\ on}$	+18	V
断态栅极电压 Off-state Gate Voltage		$V_{GS\ off}$	-5	V
总耗散功率 Total Power dissipation	$T_H = 25^{\circ}\text{C}, T_{vj} = T_{vj\ max}$	P_D	508	W

MOSFET 电特性值/ MOSFET Electrical Characteristic

Parameter	Conditions	Symbol	Value			Unit
			Min.	Typ.	Max.	
漏极-源极击穿电压 Drain-source Breakdown Voltage	$V_{GS} = 0\text{V}, T_{vj} = 25^{\circ}\text{C}, I_D = 1\text{mA}$	BV_{DS}	1200			V
零栅极电压漏极电流 Zero Gate Voltage Drain Current	$V_{DS} = 1200\text{V}, V_{GS} = 0\text{V}, T_{vj} = 25^{\circ}\text{C}$	I_{DSS}			1	mA
栅极-源极漏电流 Gate-Source Leakage Current	$V_{DS} = 0\text{V}, V_{GS} = -10\text{ to }20\text{V}$	I_{GSS}			± 500	nA
栅极阈值电压 Gate Threshold Voltage	$I_D = 60\text{mA}, V_{DS} = V_{CS}$	V_{GSth}	1.8	2.3	2.8	V
内部栅极电阻 Gate Threshold Voltage	$f = 1\text{MHz}, V_{GS} = 0\text{V}$	$R_{G(int)}$		1.88		Ω
导通电阻 Static Drain-source On Resistance	$I_D = 240\text{A}, V_{GS} = 18\text{V}$	$R_{DS(on)}$	$T_{vj} = 25^{\circ}\text{C}$		4.45	m Ω
			$T_{vj} = 150^{\circ}\text{C}$		7.85	
			$T_{vj} = 175^{\circ}\text{C}$		8.85	
输入电容 Input capacitance	$V_{DS} = 800\text{V}$ $f = 100\text{KHz}$ $V_{GS} = 0\text{V}$	C_{iss}		18.9		nF
输出电容 Output capacitance		C_{oss}		0.75		nF
反向传输电容 Reverse transfer capacitance		C_{rss}		0.078		nF
C_{oss} 储存能量 C_{oss} stored energy	$V_{DS} = 800\text{V}, V_{GS} = 0\text{V}$	E_{oss}		288		μJ
总栅极电荷 Total Gate Charge	$V_{DS} = 800\text{V}, I_D = 240\text{A}, V_{GS} = -5/+18\text{V}$	Q_G		857		nC

开通延迟时间（感性负载） Turn-on delay time (inductive load)		$T_{vj} = 25^{\circ}\text{C}$	$t_{d(on)}$		57		ns
		$T_{vj} = 150^{\circ}\text{C}$			51		
		$T_{vj} = 175^{\circ}\text{C}$			47		
上升时间（感性负载） Rise time (inductive load)		$T_{vj} = 25^{\circ}\text{C}$	t_r		34		ns
		$T_{vj} = 150^{\circ}\text{C}$			28		
		$T_{vj} = 175^{\circ}\text{C}$			29		
关断延迟时间（感性负载） Turn-off delay time (inductive load)	$V_{DS} = 600\text{V}$ $I_D = 240\text{A}$ $V_{GS} = +18/-5\text{V}$ $R_{gon} = 3.6\Omega$	$T_{vj} = 25^{\circ}\text{C}$	$t_{d(off)}$		215		ns
		$T_{vj} = 150^{\circ}\text{C}$			240		
		$T_{vj} = 175^{\circ}\text{C}$			250		
下降时间（感性负载） Fall time (inductive load)	$R_{goff} = 3.6\Omega$ $L_s = 25\text{nH}$ Inductive Load	$T_{vj} = 25^{\circ}\text{C}$	t_f		34		ns
		$T_{vj} = 150^{\circ}\text{C}$			38		
		$T_{vj} = 175^{\circ}\text{C}$			39		
开通损耗能量（每脉冲） Turn-on energy loss per pulse		$T_{vj} = 25^{\circ}\text{C}$	E_{on}		4.11		mJ
		$T_{vj} = 150^{\circ}\text{C}$			4.22		
		$T_{vj} = 175^{\circ}\text{C}$			4.40		
关断损耗能量（每脉冲） Turn-off energy loss per pulse		$T_{vj} = 25^{\circ}\text{C}$	E_{off}		5.88		mJ
		$T_{vj} = 150^{\circ}\text{C}$			6.05		
		$T_{vj} = 175^{\circ}\text{C}$			6.12		

体二极管电特性值/ Body Diode Electrical Characteristic

Parameter	Conditions		Symbol	Value			Unit
				Min.	Typ.	Max.	
正向电压 Forward Voltage	$I_{SD} = 240\text{A}, V_{GS} = -5\text{V}$	$T_{vj} = 25^{\circ}\text{C}$	V_{SD}		5.10		V
		$T_{vj} = 150^{\circ}\text{C}$			4.65		
		$T_{vj} = 175^{\circ}\text{C}$			4.58		
反向恢复电荷 Recovered charge		$T_{vj} = 25^{\circ}\text{C}$	Q_r		1.5		μC
		$T_{vj} = 150^{\circ}\text{C}$			4.0		
		$T_{vj} = 175^{\circ}\text{C}$			5.3		

反向恢复峰值电流 Peak reverse recovery current	$V_{SD} = 600V$ $I_{SD} = 240A$ $V_{GS} = -5V$	$T_{vj} = 25^{\circ}C$	I_{RM}		74		A
		$T_{vj} = 150^{\circ}C$			150		
		$T_{vj} = 175^{\circ}C$			175		
反向恢复损耗（每脉冲） Reverse recovery energy	$R_{gon} = 3.6\Omega$ $L_s = 25nH$ Inductive Load	$T_{vj} = 25^{\circ}C$	E_{rec}		0.34		mJ
		$T_{vj} = 150^{\circ}C$			1.39		
		$T_{vj} = 175^{\circ}C$			1.74		

热阻/ Thermal Resistance

Parameter	Conditions	Symbol	Value			Unit
			Min.	Typ.	Max.	
结-散热器热阻 Thermal resistance junction to heatsink	$\lambda_{grease} = 3.4W/(m^*K)$	R_{thJH}		0.295		K/W

负温度系数热敏电阻/NTC-Thermistor

Parameter	Conditions	Symbol	Value			Unit
			Min.	Typ.	Max.	
额定电阻值 Rated resistance	$T_{NTC} = 25^{\circ}C$	R_{25}		5		kΩ
R_{100} 偏差 Deviation of R_{100}	$T_{NTC} = 100^{\circ}C, R_{100} = 493 \Omega$	$\Delta R/R$	-5		5	%
B-值 B-value	$R_2 = R_{25} \exp [B_{25/100}(1/T_2 - 1/(298,15 K))]$	$B_{25/100}$		3480		K

特征参数图表/Characteristics Diagrams

输出特性 (典型)
Output characteristic (typical)
 $I_D = f(V_{DS})$
 $V_{GS} = 18V$

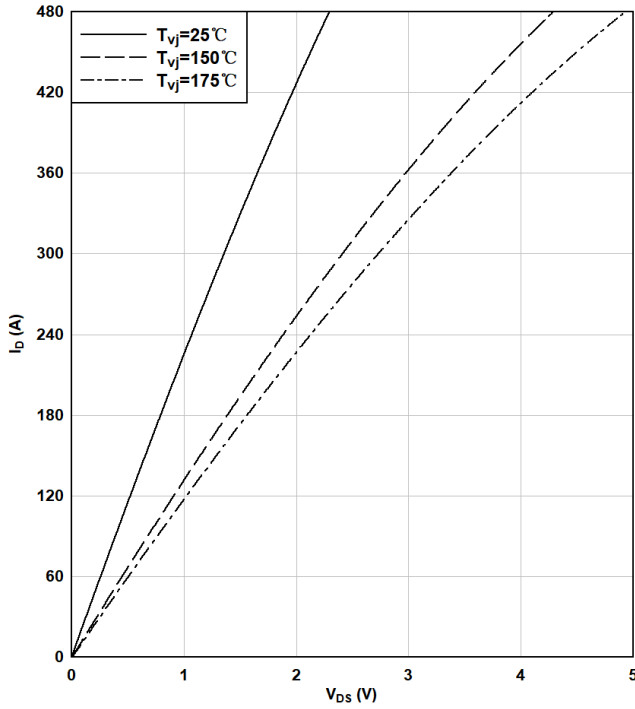

输出特性 (典型)
Output characteristic (typical)
 $I_D = f(V_{DS})$
 $T_{vj} = 175^\circ C$

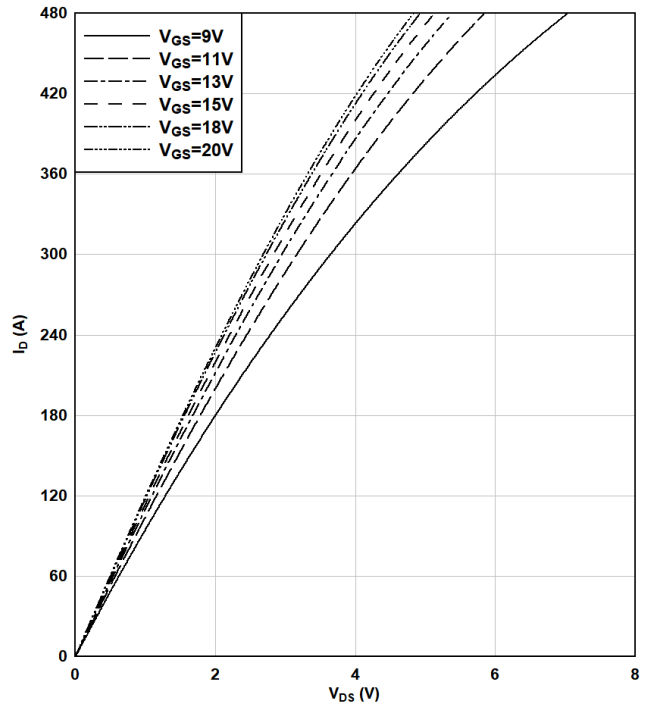

导通电阻 (典型)
Drain source on-resistance (typical)
 $R_{DS(on)} = f(I_D)$
 $V_{GS} = 18V$

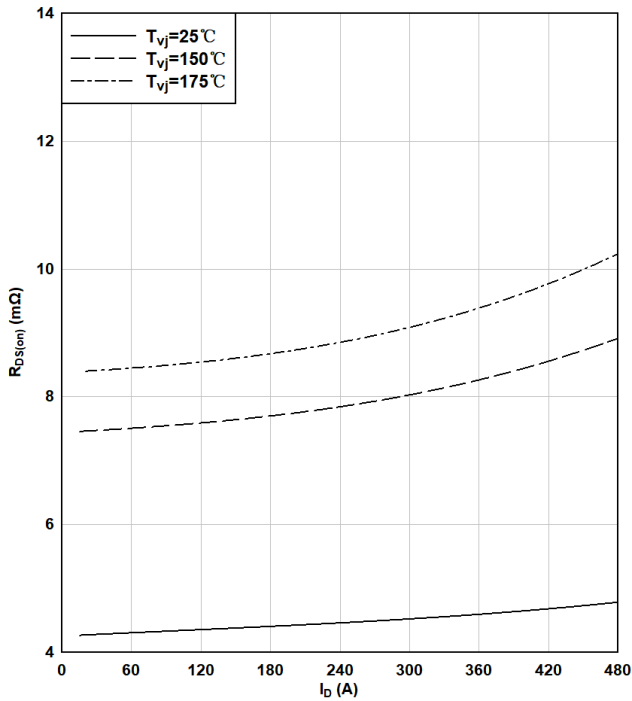

导通电阻 (典型)
Drain source on-resistance (typical)
 $R_{DS(on)} = f(T_{vj})$
 $V_{GS} = 18V, I_D = 240A$

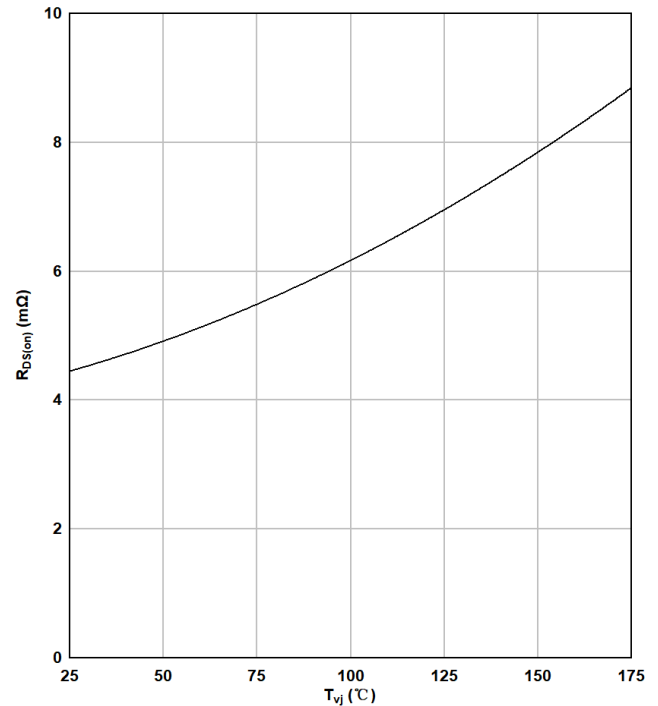

特征参数图表/Characteristics Diagrams

传输特性 (典型)
Transfer characteristic (typical)
 $I_D = f(V_{GS})$
 $V_{DS} = 20V$

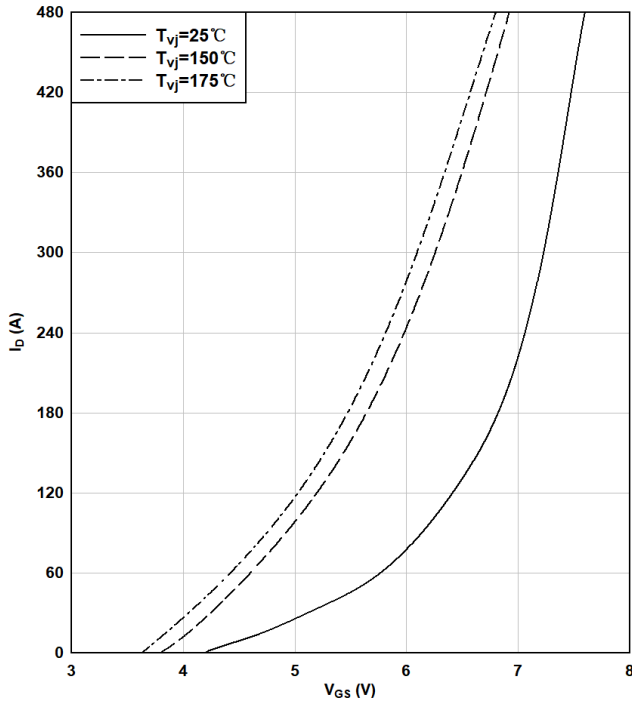

阈值电压 (典型)
Gate-source threshold voltage (typical)
 $V_{GSth} = f(T_{vj})$
 $I_D = 60mA$

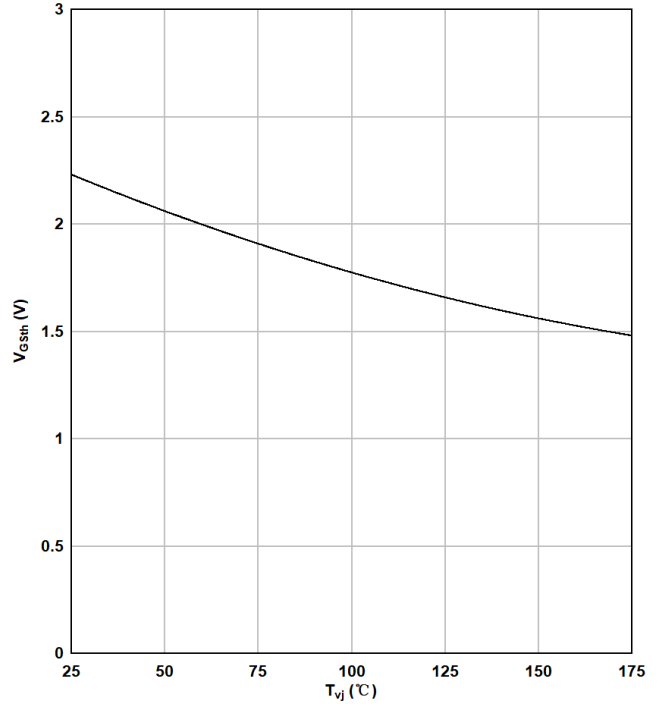

栅极电荷曲线 (典型)
Capacitance Characteristic (typical)
 $V_{GS} = f(Q_G)$
 $V_{DS} = 800V, I_D = 240A$

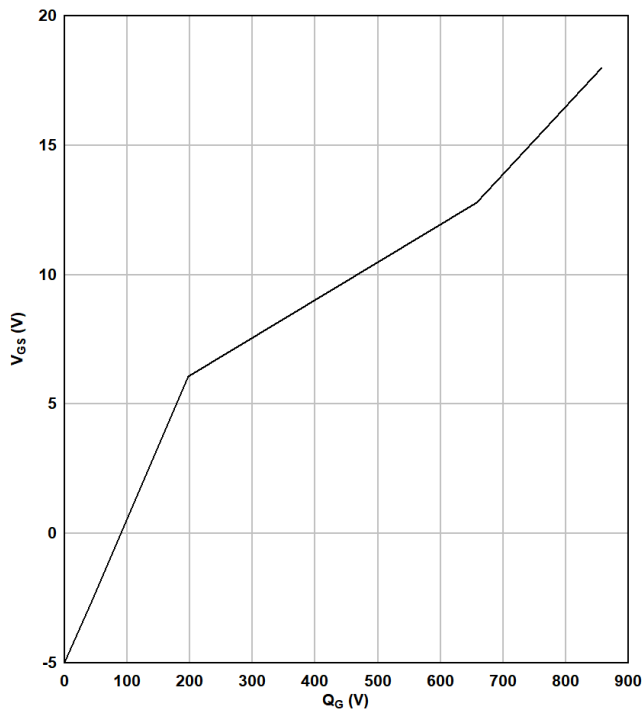

电容曲线 (典型)
Capacitance Characteristic (典型)
 $C = f(V_{DS})$
 $V_{GS} = 0V, f = 100KHz$

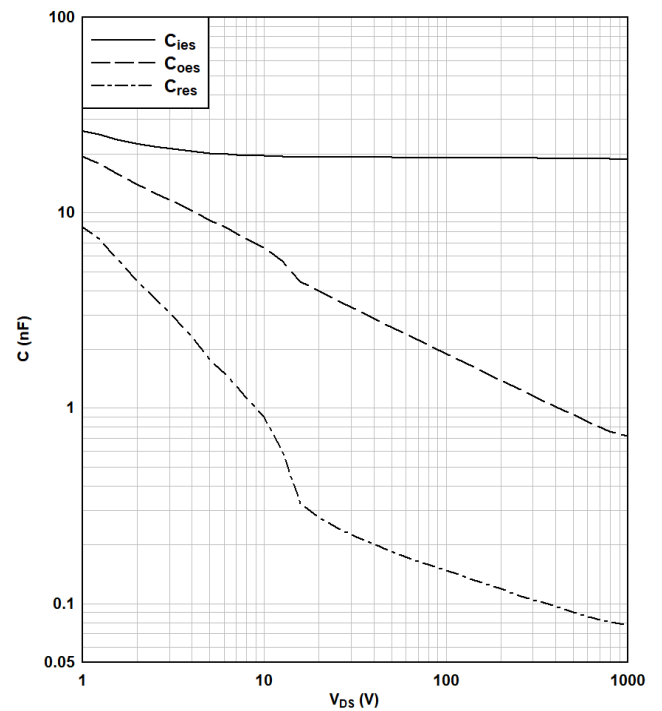

特征参数图表/Characteristics Diagrams

开关损耗（典型）

Switching losses (typical)

$E = f(I_D)$

$V_{DS} = 600V, R_{Gon} = 3.6\Omega, R_{Goff} = 3.6\Omega, V_{GS} = +18/-5V$

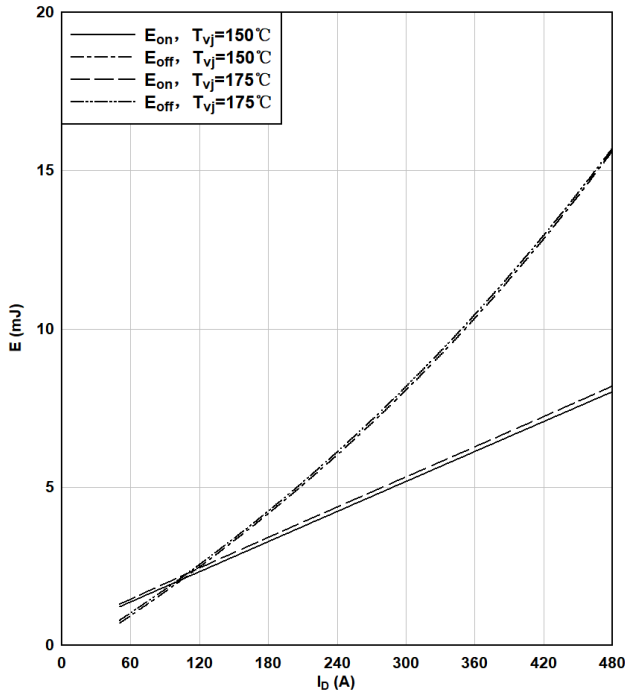

开关损耗（典型）

Switching losses (typical)

$E = f(R_G)$

$I_D = 240A, V_{DS} = 600V, V_{GS} = +18/-5V$

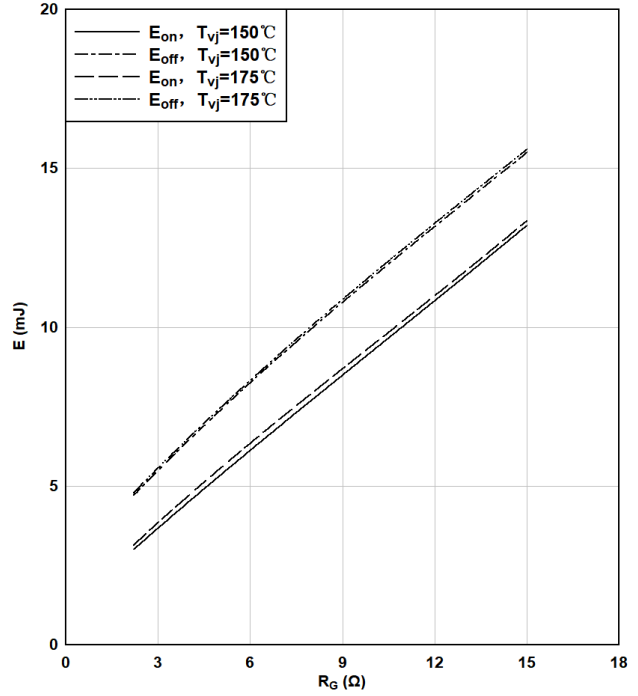

正向特性（典型），体二极管，

Forward characteristic (typical), Body Diode

$I_{SD} = f(V_{SD})$

$V_{GS} = -5V$

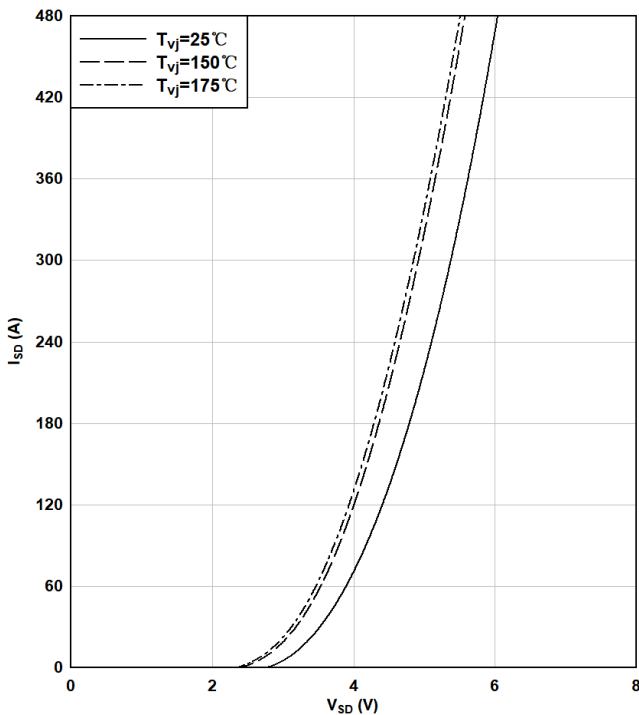

开关损耗（典型），体二极管，

Switching losses (typical), Body Diode

$E_{rec} = f(I_{SD})$

$V_{DS} = 600V, R_{Gon} = 3.6\Omega$

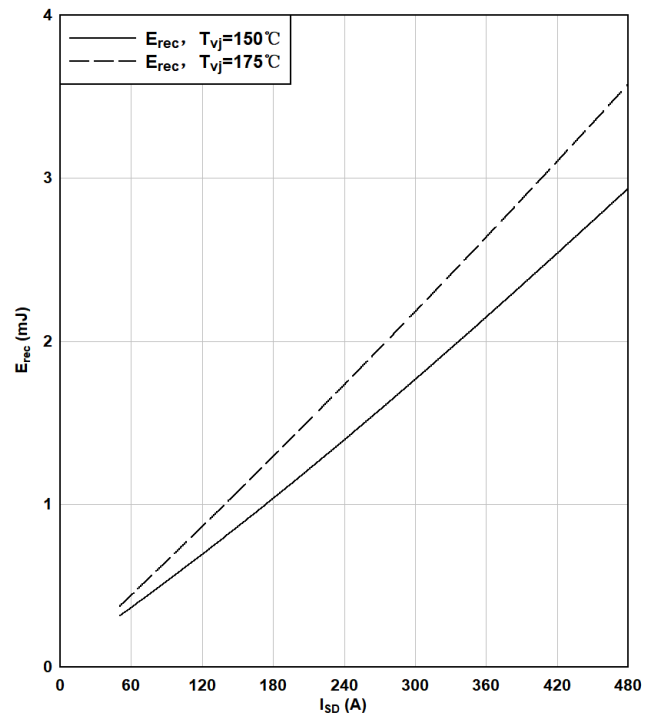

特征参数图表/Characteristics Diagrams

开关损耗 (典型), 体二极管
Switching losses (typical), Body Diode
 $E_{rec} = f(R_G)$
 $I_{SD} = 240A, V_{DS} = 600V$

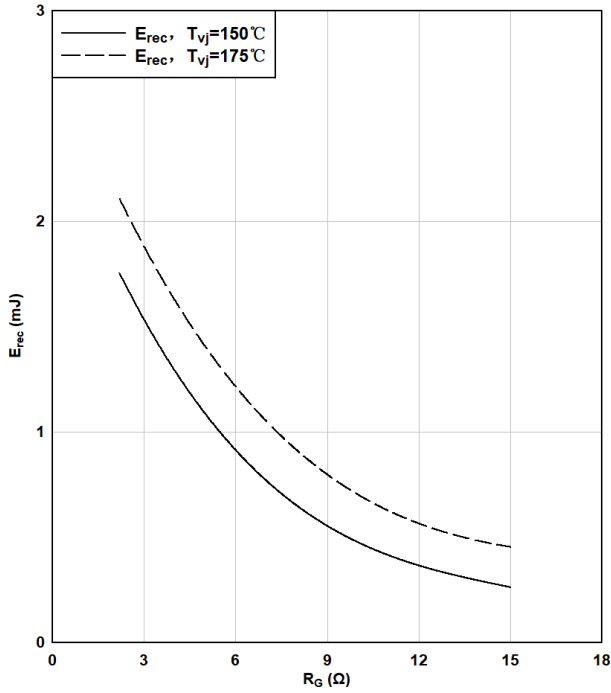

反偏安全工作区 IGBT, 逆变器
Reverse bias safe operating area IGBT, Inverter
 $I_D = f(V_{DS})$
 $R_{Goff} = 3.6\Omega, T_{vj}=175^\circ C, V_{GS} = +18/-5V$

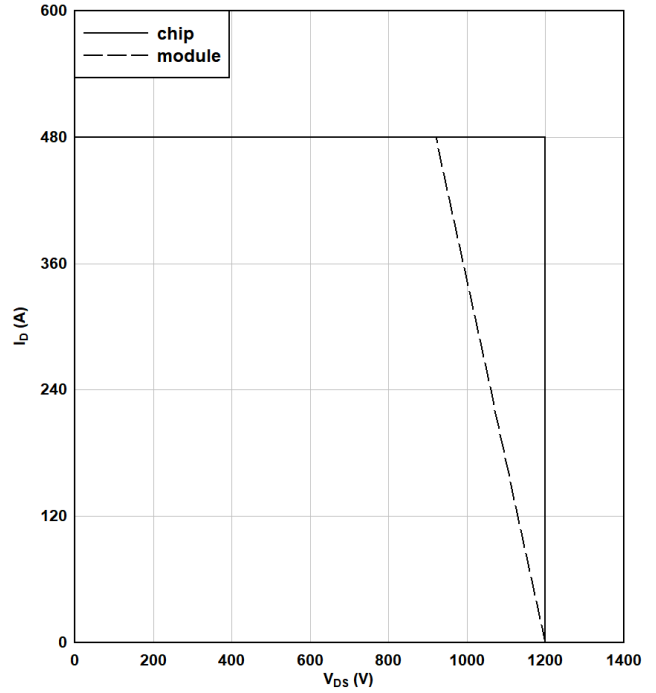

瞬态热阻抗
Transient thermal impedance
 $Z_{thJH} = f(t)$

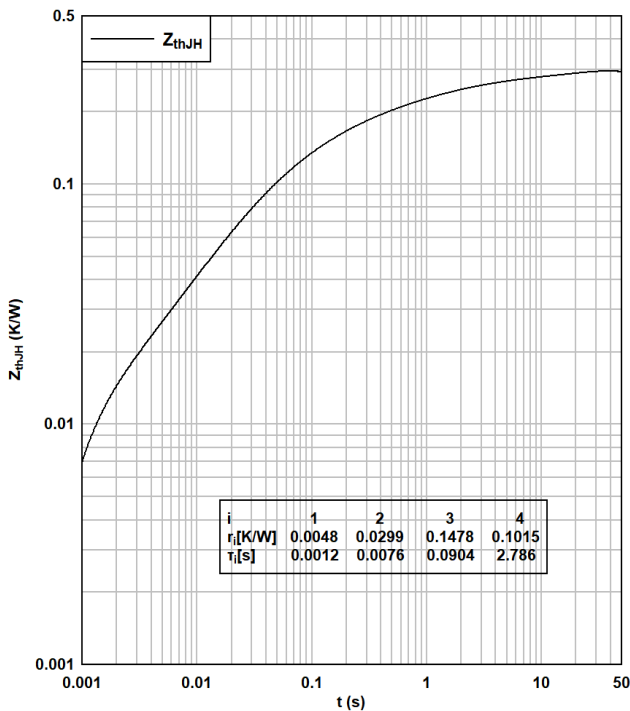

负温度系数热敏电阻温度特性
NTC-Thermistor-temperature characteristic (typical)
 $R = f(T_c)$

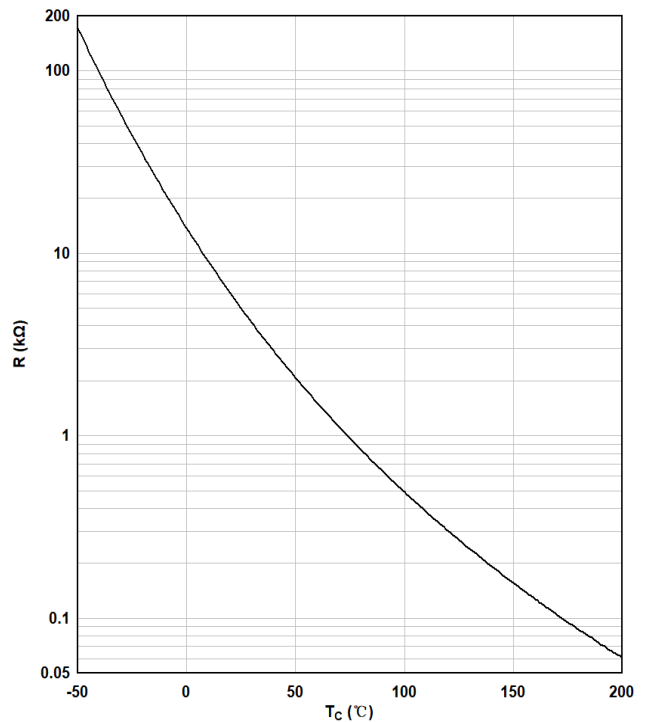

电路拓扑图/ Circuit Diagram

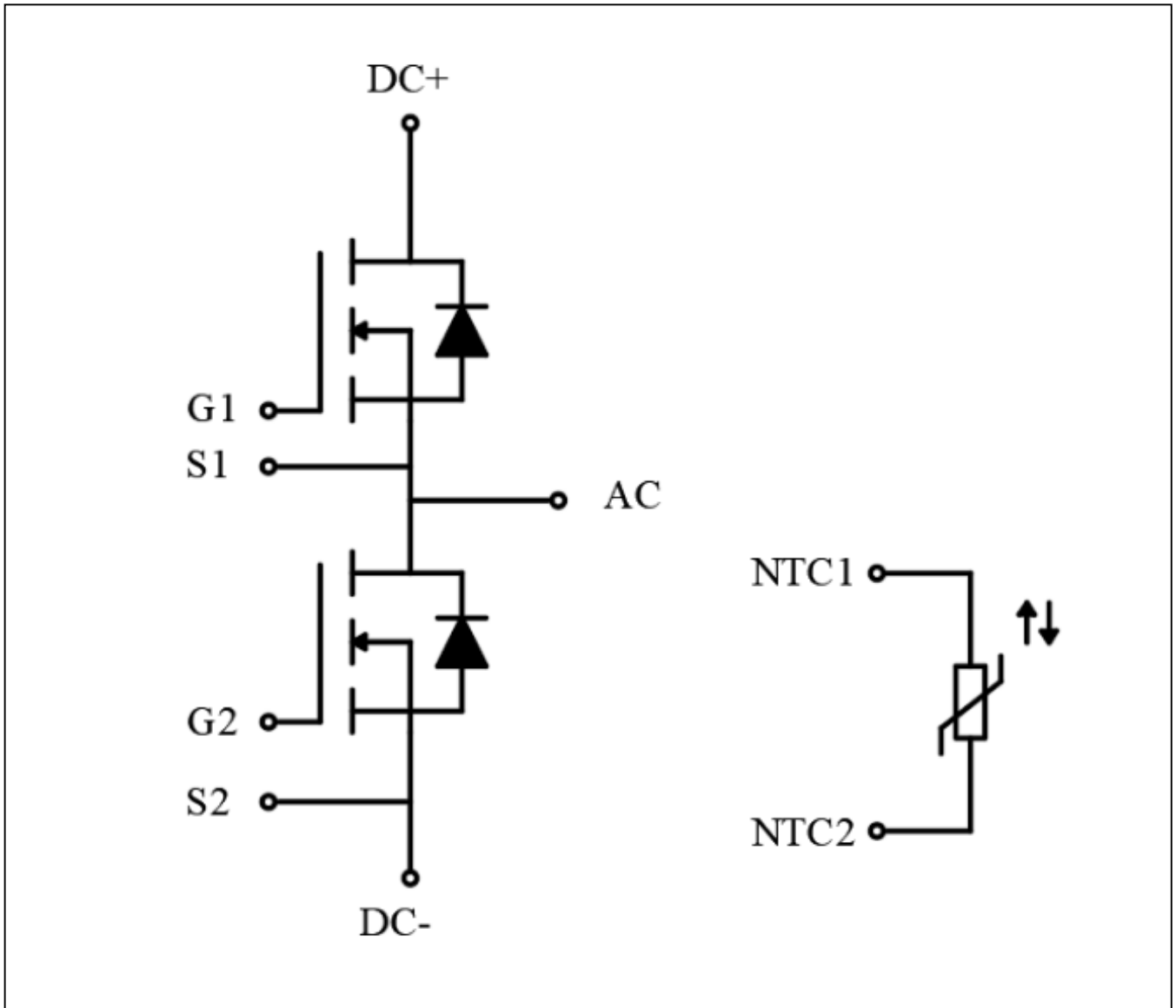

封装尺寸/ Package Outlines

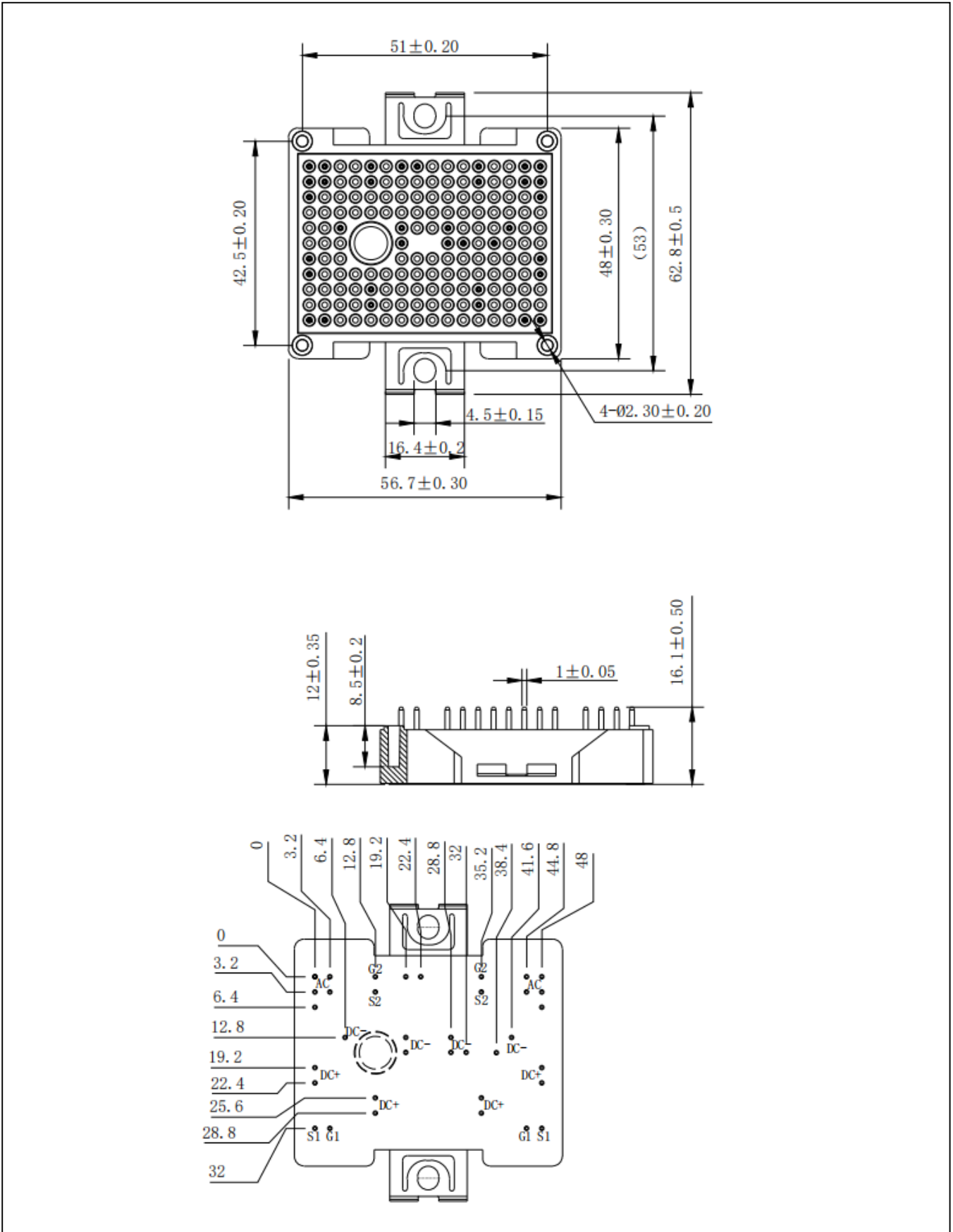

模块标签信息/ Module Marking Information

Marking Diagram

AMS004H12P2C3RA = Specific Device

P2CQ25240060010= Lot Traceability

ACP-2 = Package Type

声明与使用条件/ Notices and conditions of use

1. 阿基米德保留手册的更改权；

Archimedes reserves the right to change the manual;

2. 本手册中提供的数据一部分为产品的典型值，实际出厂测试的数据与典型值略有差异，但我司保证这些差异不会影响产品的正常使用，如果产品信息发生变更，我司会及时更新手册，请随时关注；

Part of the data provided in this manual is the typical value of the product, the actual factory test data and the typical value are slightly different, but our company guarantees that these differences will not affect the normal use of the product, if the product information changes, our company will update the manual in time, please pay attention at any time;

3. 在应用我司产品时请不要超过产品的最大额定值，否则我司无法保证产品应用的可靠性；

When applying our products, please do not exceed the maximum rating of the product, otherwise our company can not guarantee the reliability of the product application;

4. 产品在使用时，严禁触碰，断电后确认无残余电荷且产品已完全冷却后，才可以在有静电防护措施下触碰产品；

When the product is in use, it is strictly forbidden to touch the product. After power off, it is confirmed that there is no residual charge and the product has been completely cooled, and it can only be touched under electrostatic protection measures;

5. 购买产品时请认准我司商标，如有疑问请与本司联系。

Please look for our trademark when purchasing products. If you have any questions, please contact us.